

INVERTER

FR-D800

Instruction Manual (Functional Safety) (Standard model)

CONTENTS

1. GENERAL DESCRIPTION.....	3
2. INSTALLATION AND WIRING	4
3. EXAMPLE OF SAFETY SYSTEM CONFIGURATION.....	8
4. TEST AND CHECKING FAILURE	11
5. SAFETY PARAMETERS OF FR-D800	12

Compliance with the EU Machinery Directive – Functional Safety

To achieve functional safety, any work on the product such as wiring and inspections must be performed according to the Instruction Manual by technicians who took a safety standard training.

WARNING

- Any misuse of safety function could lead to personal injury or death, property damage, or economic loss. To ensure that the system complies fully with requirement of safety, make a system-level risk assessment. Mitsubishi Electric cannot assume responsibility for any system to comply with safety directive.
- To avoid an electric shock hazard, verify that the voltage on the bus capacitors has discharged before performing any work on the inverter. Measure the DC bus voltage between the terminals P/+ and N/- or at test points (refer to your inverter's Instruction Manual for locations and discharging time). The voltage must be zero.
- The safety stop function do not isolate electrically between the inverter and the motor. To avoid an electric shock hazard, verify that the voltage on the bus capacitors has discharged before wiring or inspection of the motor. Measure the DC bus voltage between the terminals P/+ and N/- or at test points (refer to your inverter's Instruction Manual for locations and discharging time). The voltage must be zero.

CAUTION

- The information of this manual is merely a guide for proper installation.
- Mitsubishi Electric cannot assume responsibility for the compliance or the noncompliance to any code, national, local, or otherwise for the proper installation of this equipment.
- A hazard of personal injury and/or equipment damage exists if codes are ignored during installation.

1 GENERAL DESCRIPTION

◆ Features

The safety stop function of the Mitsubishi Electric FR-D800 inverter can be used to prevent the inverter from supplying rotational energy to motors. Dual input terminals S1 and S2 can be used to cut off the gate-drive power to the IGBT.

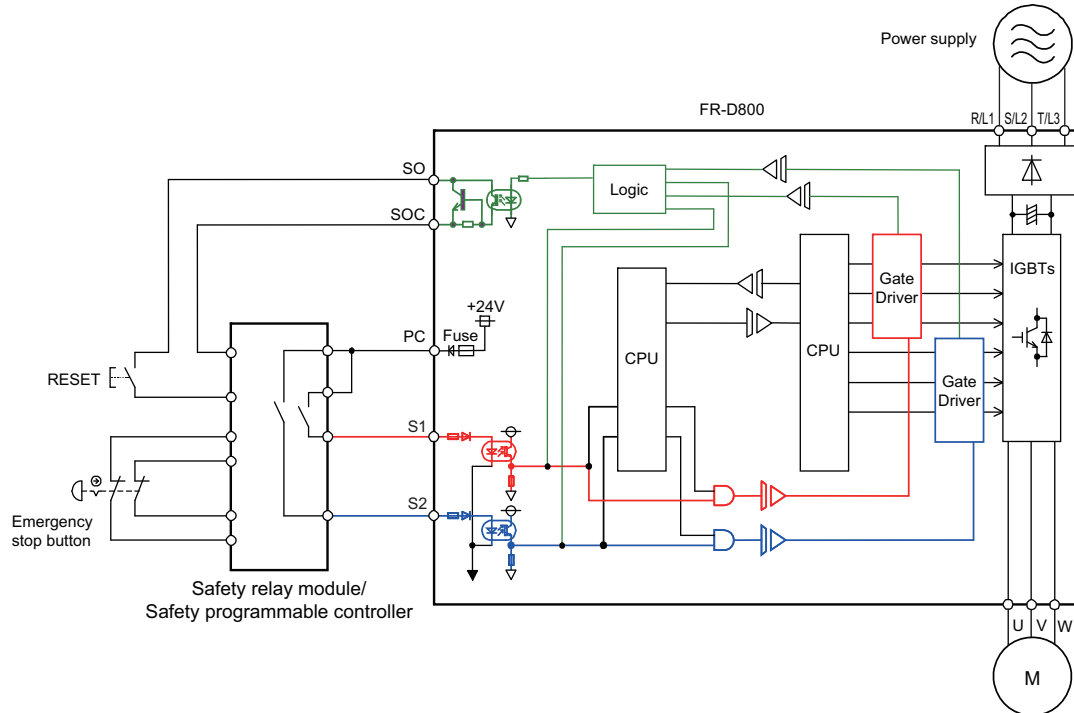

Figure 1 FR-D800 safety stop function diagram

◆ Safety stop function with SIL 2 certification

Mitsubishi Electric FR-D800 series general-purpose inverters have met the SIL 2 requirements of the international standard IEC 61508 for functional safety.

Table 1 Compliance with SIL 2

	FR-D800
Safety performance (Standards certified by a third-party certification body)	ISO 13849-1 Category 3/PLd IEC 62061 / IEC 61800-5-2 / IEC 61508 SIL2 IEC 60204-1 / IEC 61800-5-2 Stop category 0

⚠ WARNING

- Disconnecting the power to the gate driver by the safety stop function does not isolate electrically between the inverter and the motor. To avoid an electric shock hazard, disconnect power to the inverter and verify that the main circuit capacitor voltage is zero (across terminals P/+ and N/-) before performing any work on the motor (refer to your inverter's Instruction Manual for discharging time).
- The misuse of safety function leads to personal injury or death, property damage, or economic loss. To ensure that the system complies fully with requirement of safety, make a system-level risk assessment. Mitsubishi Electric cannot assume responsibility for any system to comply with safety standards.

2 INSTALLATION AND WIRING

⚠ CAUTION

- The following information is merely a guide for proper installation. Mitsubishi Electric cannot assume responsibility for the compliance or the noncompliance to any code, national, local, or otherwise for the proper installation of this equipment. A hazard of personal injury and/or equipment damage exists if codes are ignored during installation.
- Ensure the safety relay unit and the inverter are mounted closely in an enclosure meeting IP54 and all interconnection wiring is short and protected against open and short circuit faults. Refer ISO/IEC 13849-2.

◆ Installation

The safety stop function of the Mitsubishi Electric FR-D800 inverter should be used under the following conditions and environment.

Table 2 Conditions and environment for using the safety stop function

Item		Condition
Surrounding air temperature	SLD, ND	-20 to +60°C (non-freezing) SLD rating: The rated current must be reduced at a temperature above 40°C. ND rating: The rated current must be reduced at a temperature above 50°C.
Ambient humidity		With circuit board coating (conforming to IEC 60721-3-3 3C2/3S2): 95% RH or less (non-condensing), Without circuit board coating: 90% RH or less (non-condensing)
Storage temperature		-40 to +70°C*1
Vibration		5.9 m/s ² or less at 10 to 55 Hz (directions of X, Y, Z axes)
Altitude		Maximum 3000 m.*2
Atmosphere		Indoors (free from corrosive gas, flammable gas, oil mist, dust and dirt)
Overtoltage category		III or lower
Pollution degree		II or lower
Mounting		Wall mounting / vertical orientation

*1 Temperature applicable for a short time, e.g. in transit.

*2 For the installation at an altitude above 1,000 m, derate the rated current 3% per 500 m.

⚠ WARNING

- To avoid an electric shock hazard, insert the magnetic contactor (MC) between power source and inverter.
- Open the contact of MC and keep away from the inverter for discharging time (refer to your inverter's Instruction Manual for information) before performing any work on the inverter. And verify that the voltage on the bus capacitors has discharged before measuring the DC bus voltage between the terminals P/+ and N/- or at test points (refer to your inverter's Instruction Manual for locations). The voltage must be zero.

⚠ CAUTION

- In order to meet safety standards, a safety relay module compliant with ISO 13849-1 safety category 3 or higher shall be used in conjunction with the inverter (refer to [page 10](#)). In addition, all other components in the safety stop loop shall be 'safety approved' types.
- To avoid system faults, check the safety stop function at least once per year. Also, check the safety stop function at system installation, any software changes, and parameter setting changes. For details, refer to Chapter 4 TEST AND CHECKING FAILURE.

◆ Wiring

The safety related terminals are described in Table 3 and Table 4.

Table 3 Safety related terminals

Terminal symbol	Terminal name	Terminal function description*2	Rating*1
S1	Safety stop input (Channel 1)	For input of safety stop channel 1 Between S1 and PC OFF: In safety stop mode ON: Other than the safety stop mode	Input resistance: 4.7 kΩ Input current: 4 to 6 mADC (In case of 24 VDC input)
S2	Safety stop input (Channel 2)	For input of safety stop channel 2 Between S2 and PC OFF: In safety stop mode ON: Other than the safety stop mode	
PC	24 VDC power supply	-	Output voltage: 22 to 26.5 V Output current: 100 mA max.
SO	Inverter running status	Used for internal safety circuit failure detection and alarm (open collector output). Between SO and SOC OFF: Internal safety circuit failure or alarm detected ON: No internal safety circuit failure Note: Terminal SO cannot be used for safety signals in a safety system. Use terminal SO to output a fault and to prevent restarting of the inverter.	Load: 24 VDC / 0.1 A max. Voltage drop: 3.4 V max. (In case of 'ON' state)
SOC	Safety monitor output terminal common	Common terminal for terminal SO	

*1 Specifications for conforming to safety standards.

*2 ON: The transistor is conducted. OFF: The transistor is not conducted.

Table 4 Truth table of safety related signals

Input power	Internal safety circuit status	Input terminal *1 *2		Output terminal SO	Output signal *8 *9 *10		Inverter running status	Operation panel indication	
		S1	S2		SAFE	SAFE2		E.SAF*6	SA*7
OFF	—	—	—	OFF	OFF	OFF	Output shutoff (Safe state)	Not displayed	Not displayed
ON	Normal	ON	ON	ON*3	OFF	ON*3	Drive enabled	Not displayed	Not displayed
	Normal	ON	OFF	OFF*4	OFF*4	OFF*4	Output shutoff (Safe state)	Displayed	Displayed
	Normal	OFF	ON	OFF*4	OFF*4	OFF*4	Output shutoff (Safe state)	Displayed	Displayed
	Normal	OFF	OFF	ON*3	ON*3	ON*3	Output shutoff (Safe state)	Not displayed	Displayed
	Fault	ON	ON	OFF	OFF	OFF	Output shutoff (Safe state)	Displayed	Not displayed*5
	Fault	ON	OFF	OFF	OFF	OFF	Output shutoff (Safe state)	Displayed	Displayed
	Fault	OFF	ON	OFF	OFF	OFF	Output shutoff (Safe state)	Displayed	Displayed
	Fault	OFF	OFF	OFF	OFF	OFF	Output shutoff (Safe state)	Displayed	Displayed

*1 ON: The transistor is conducted. OFF: The transistor is not conducted.

*2 When not using the safety stop function, short across terminals S1 and PC, and S2 and PC to use the inverter. (In the initial status, terminals S1 and PC, and S2 and PC are respectively shorted with shorting wires.)

*3 If any of the faults shown in the following table occurs, terminal SO, the SAFE signal, and the SAFE2 signal are turned OFF.

Error definition	Operation panel indication
Internal storage device fault	E.PE6
Parameter storage device fault (control circuit board)	E.PE
Retry count excess	E.RET
Parameter storage device fault (main circuit board)	E.PE2
Safety circuit fault	E.SAF

Error definition	Operation panel indication
Overspeed occurrence	E.OS
CPU fault	E.CPU
	E.5 to E.7
Internal circuit fault	E.13

*4 When the internal safety circuit is operated normally (no fault occurs), terminal SO, the SAFE signal, and the SAFE2 signal remain ON until "E.SAF" is displayed. Terminal SO, the SAFE signal, and the SAFE2 signal are turned OFF when "E.SAF" is displayed.

*5 SA is displayed when the terminals S1 and S2 are identified as OFF due to the internal safety circuit failure.

*6 If another fault occurs at the same time as E.SAF, the other fault can be displayed.

*7 If another warning occurs at the same time as SA, the other warning can be displayed.

*8 The ON/OFF state of the output signal is the one for the positive logic. The ON and OFF are reversed for the negative logic.

*9 To assign the functions of the SAFE signal and SAFE2 signal to output terminals, set either value shown in the following table. To output the signal via a physical terminal, the function can be assigned to **Pr.190 to Pr.192**. (The FU signal is initially assigned to terminal R+/FU.) To output the signal via communication, the function can be assigned also to **Pr.190 to Pr.196** (Output terminal function selection) using communication protocols (only "80 or 81" are available for **Pr.193 to Pr.196**). For details, refer to the Instruction Manual (Communication).

Output signal	Pr.190 to Pr.196 settings	
	Positive logic	Negative logic
SAFE	80	180
SAFE2	81	181

*10 The use of the SAFE signal and SAFE2 signal has not been certified for compliance with safety standards.

NOTE

- The response time from safety stop signal input to drive shutoff (safe state) is faster than 4 ms.
- Hold the ON or OFF status for 2 ms or longer to input signal to terminal S1 or S2. Signal input shorter than 2 ms is not recognized.

◆Wiring and ferrule terminal specifications

Table 5 Wiring and Ferrule terminal specifications

Cable gauge (mm ²)	Ferrule terminal model*1	Crimping tool name*1
0.3	AI 0,34-10TQ	CRIMPFOX 6
0.5	AI 0,5-10WH	
0.75	AI 0,75-10GY	
1	AI 1-10RD	
1.25 / 1.5	AI1,5-10BK	
0.75 (for two wires)	AI TWIN 2 X 0,75-10GY	

*1 Ferrule terminals and the tool are distributed by Phoenix Contact Co., Ltd.

◆Shorting wire

The shorting wire are installed between terminals S1/S2 and PC in the initial status as shown in Figure 2. Remove the shorting wires and connect the safety relay module when using the safety stop function.

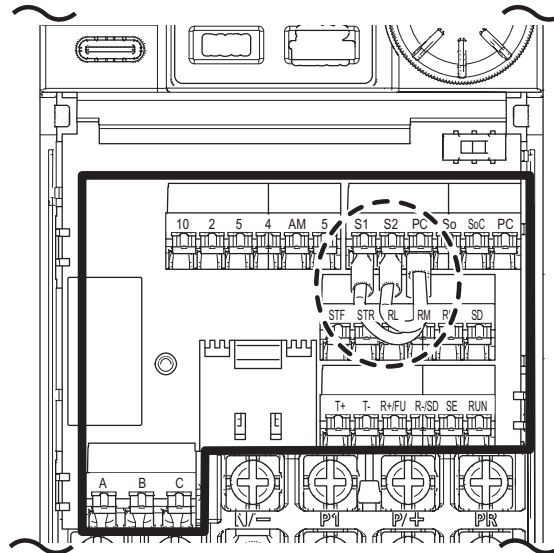

Figure 2 Shorting wire

3 EXAMPLE OF SAFETY SYSTEM CONFIGURATION

◆FR-D800 configuration example

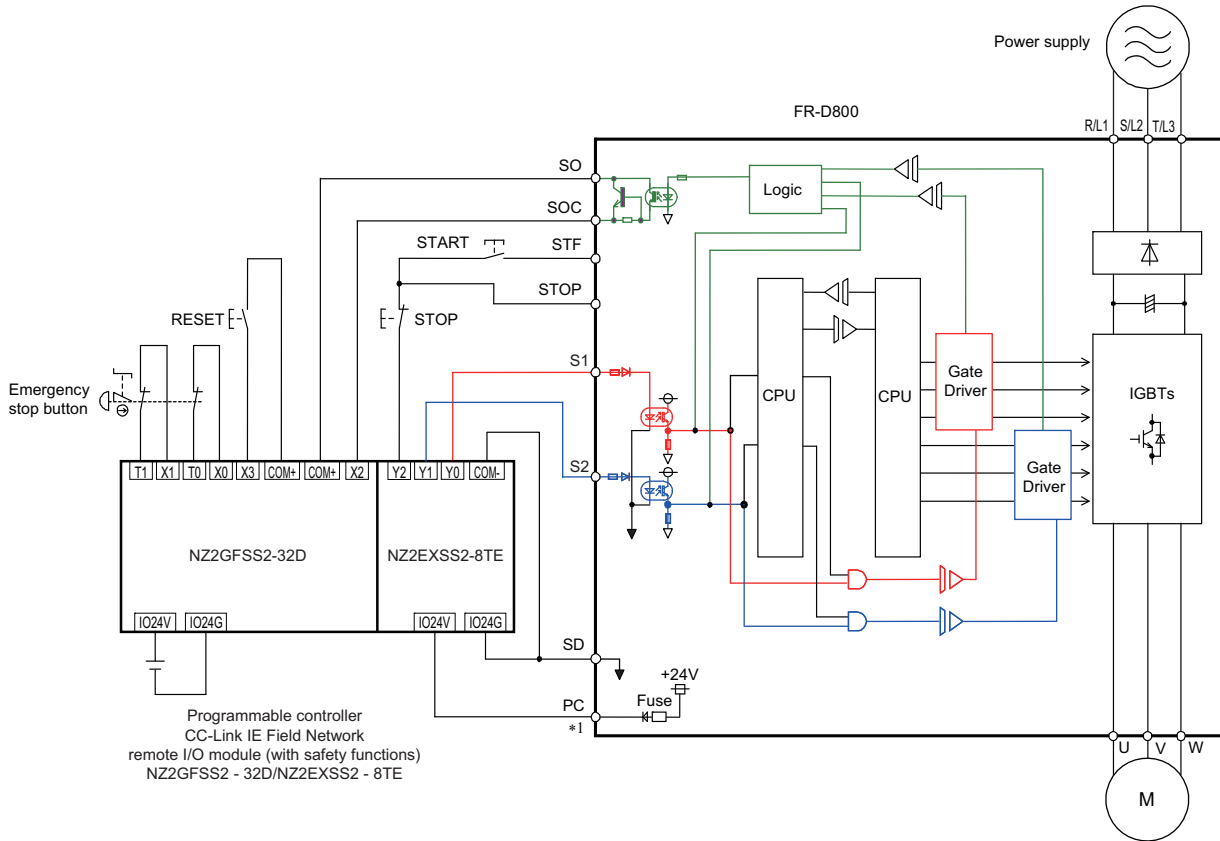

Figure 3 Safety system example of the FR-D800 inverter

*1 When the control logic is the sink logic, the common terminal is terminal SD.

NOTE

- When starting up the system operation, press the RESET switch to reset the safety stop function first.
- In the above configuration, after resetting the emergency stop button, the inverter will be in the safe-state until the RESET switch is pressed.

CAUTION

- To prevent restart of the inverter when the power is restored after a power failure, 3-wire connection is recommended for the START/STOP control. In case of 2-wire connection and using latching type switch to short between STF and SD/PC for starting, ensure the compliance with safety standards for the restarting when the inverter power is restored after a power failure.

◆ Multiple inverter configuration example

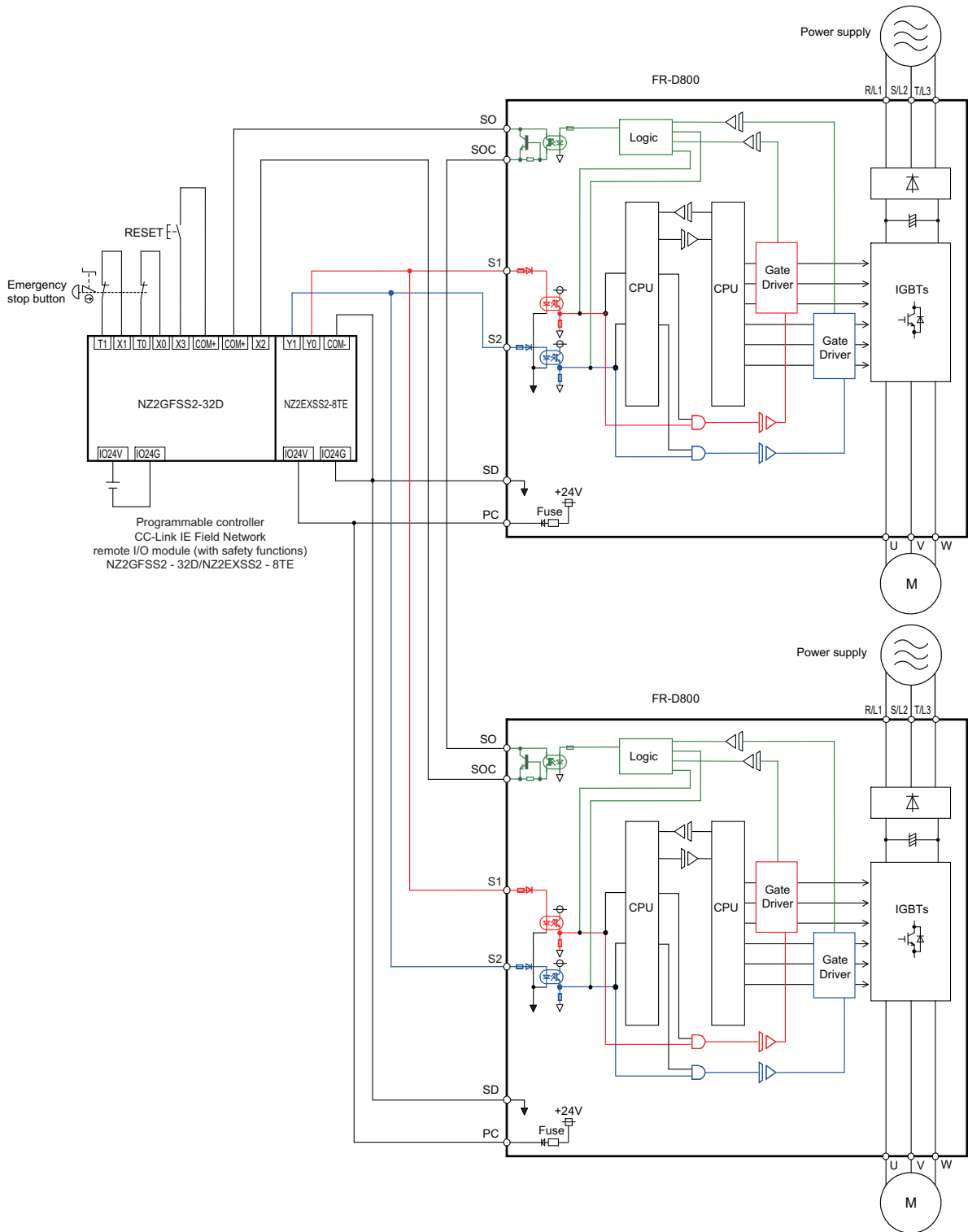

Figure 4 When using multiple safety stop function inverters (FR-D800)

NOTE

- Some models cannot be used together because their control logics are different. Refer to the Safety Stop Function Manual of each model.

◆ Safety controller configuration example

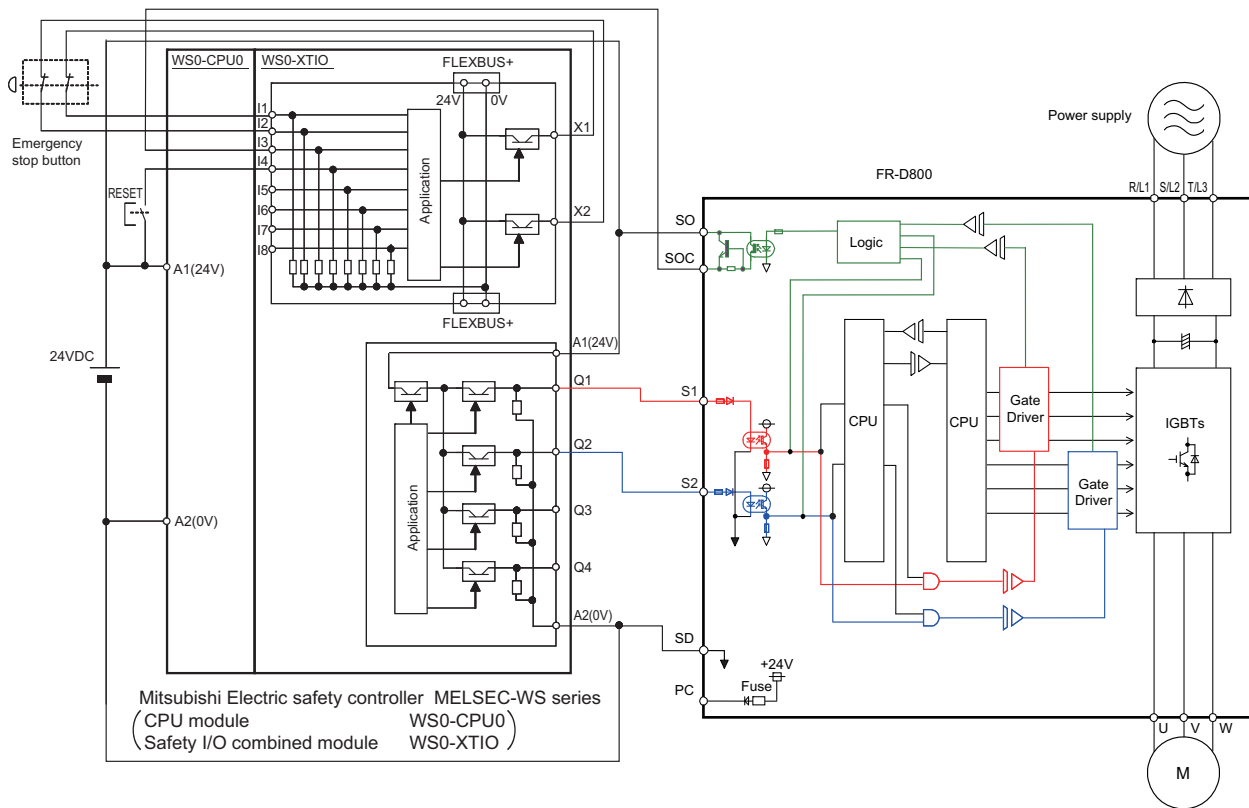

Figure 5 Safety system example of the FR-D800 inverter

NOTE

- When starting up the system operation, press the RESET switch to reset the safety stop function first.
- In the above configuration, after resetting the emergency stop button, the inverter will be in the safe-state until the RESET switch is pressed.

4 TEST AND CHECKING FAILURE

⚠ CAUTION

- To avoid system faults, check the safety stop function at least once per year. Also, check the safety stop function at system installation, any software changes, and parameter setting changes.

◆ I/O status and inverter operation

The inverter's safety related I/O status obeys the following truth table.

Table 6 Truth table of safety related signals

Input power	Internal safety circuit status	Input terminal *1 *2		Output terminal	Output signal *8 *9 *10		Inverter running status	Operation panel indication	
		S1	S2	SO	SAFE	SAFE2		E.SAF*6	SA*7
OFF	—	—	—	OFF	OFF	OFF	Output shutoff (Safe state)	Not displayed	Not displayed
ON	Normal	ON	ON	ON*3	OFF	ON*3	Drive enabled	Not displayed	Not displayed
	Normal	ON	OFF	OFF*4	OFF*4	OFF*4	Output shutoff (Safe state)	Displayed	Displayed
	Normal	OFF	ON	OFF*4	OFF*4	OFF*4	Output shutoff (Safe state)	Displayed	Displayed
	Normal	OFF	OFF	ON*3	ON*3	ON*3	Output shutoff (Safe state)	Not displayed	Displayed
	Fault	ON	ON	OFF	OFF	OFF	Output shutoff (Safe state)	Displayed	Not displayed*5
	Fault	ON	OFF	OFF	OFF	OFF	Output shutoff (Safe state)	Displayed	Displayed
	Fault	OFF	ON	OFF	OFF	OFF	Output shutoff (Safe state)	Displayed	Displayed
	Fault	OFF	OFF	OFF	OFF	OFF	Output shutoff (Safe state)	Displayed	Displayed

*1 ON: The transistor is conducted. OFF: The transistor is not conducted.

*2 When not using the safety stop function, short across terminals S1 and PC, and S2 and PC to use the inverter. (In the initial status, terminals S1 and PC, and S2 and PC are respectively shorted with shorting wires.)

*3 If any of the faults shown in the following table occurs, terminal SO, the SAFE signal, and the SAFE2 signal are turned OFF.

Error definition	Operation panel indication
Internal storage device fault	E.PE6
Parameter storage device fault (control circuit board)	E.PE
Retry count excess	E.RET
Parameter storage device fault (main circuit board)	E.PE2
Safety circuit fault	E.SAF

Error definition	Operation panel indication
Overspeed occurrence	E.OS
CPU fault	E.CPU
	E.5 to E.7
Internal circuit fault	E.13

*4 When the internal safety circuit is operated normally (no fault occurs), terminal SO, the SAFE signal, and the SAFE2 signal remain ON until "E.SAF" is displayed. Terminal SO, the SAFE signal, and the SAFE2 signal are turned OFF when "E.SAF" is displayed.

*5 SA is displayed when the terminals S1 and S2 are identified as OFF due to the internal safety circuit failure.

*6 If another fault occurs at the same time as E.SAF, the other fault can be displayed.

*7 If another warning occurs at the same time as SA, the other warning can be displayed.

*8 The ON/OFF state of the output signal is the one for the positive logic. The ON and OFF are reversed for the negative logic.

*9 To assign the functions of the SAFE signal and SAFE2 signal to output terminals, set either value shown in the following table. To output the signal via a physical terminal, the function can be assigned to Pr.190 to Pr.192. (The FU signal is initially assigned to terminal R+/FU.) To output the signal via communication, the function can be assigned also to Pr.190 to Pr.196 (Output terminal function selection) using communication protocols (only "80 or 81" are available for Pr.193 to Pr.196). For details, refer to the Instruction Manual (Communication).

Output signal	Pr.190 to Pr.196 settings	
	Positive logic	Negative logic
SAFE	80	180
SAFE2	81	181

*10 The use of the SAFE signal and SAFE2 signal has not been certified for compliance with safety standards.

NOTE

- The response time from safety stop signal input to drive shutoff (safe state) is faster than 4 ms.
- Hold the ON or OFF status for 2 ms or longer to input signal to terminal S1 or S2. Signal input shorter than 2 ms is not recognized.

◆ Diagnostic

If a failure is detected, the FR-D800 inverter outputs a fault signal and 'E.SAF' is indicated at the display.

When the FR-D800 inverter outputs a fault signal, take following actions.

- 1) Check that the input signal logic is the same between S1-PC and S2-PC. If these are different, correct the input signal and reset the FR-D800 inverter.
- 2) Disconnect the wires from terminals S1, S2, and PC, then reset or turn OFF and ON the power. If the 'SA' is indicated on the operation panel, there is a failure in the system except for the FR-D800 inverter. When 'E.SAF' is indicated and a fault signal is output, a fault may be occurring in the FR-D800 inverter.

◆ Self diagnostic test

The FR-D800 inverter has the self-diagnostic test function at power-ON.

If the FR-D800 inverter outputs a fault signal (SA, E.SAF) at power-ON, take the action described above.

◆ Operation check procedure

Check the operation of the safety stop function as follows.

- 1) Change and check the I/O state between S1-PC and S2-PC shown in Table 6.
- 2) If the inverter operation differs from the one shown in Table 6, the FR-D800 may have a fault.
- 3) If the inverter operates as described in Table 6, check the system performance. Press the emergency switch, press the start/restart button while a failure is detected (SO-SOC opened), and so on.
- 4) Finally clear the fault history of the FR-D800 inverter (see the Instruction Manual (Maintenance) for how to clear the fault history).

5 SAFETY PARAMETERS OF FR-D800

The safety parameters of the FR-D800 inverter are depicted as follows.

Table 7 Safety parameters of FR-D800

Parameter	Value
	Safety Integrity Level (SIL) 2
PFD _{AVG}	2.50×10^{-3}
PFHD	1.50×10^{-8}
PL	d
MTTFD	100 years
DC _{AVG}	60%

MEMO

REVISIONS

Revision date	Manual number	Revision
Dec. 2024	BCN-A23498-007-A(E)	First edition

HEADQUARTERS

Mitsubishi Electric Europe B.V. **EUROPE**
 Mitsubishi-Electric-Platz 1
D-40882 Ratingen
 Phone: +49 (0)2102 / 486-0
 Fax: +49 (0)2102 / 486-1120

Mitsubishi Electric Europe B.V. **CZECH REP.**
 Pekařská 621/7
CZ-155 00 Praha 5
 Phone: +420 255 719 200
 Fax: +420 251 551 471

Mitsubishi Electric Europe B.V. **FRANCE**
 25, Boulevard des Bouvets
F-92741 Nanterre Cedex
 Phone: +33 (0)1 / 55 68 55 68
 Fax: +33 (0)1 / 55 68 57 57

Mitsubishi Electric Europe B.V. **IRELAND**
 Westgate Business Park, Ballymount
IRL-Dublin 24
 Phone: +353 (0)1 4198800
 Fax: +353 (0)1 4198890

Mitsubishi Electric Europe B.V. **ITALY**
 Viale Colleoni 7 Palazzo Sirio
I-20864 Agrate Brianza (MB)
 Phone: +39 039 / 60 53 1
 Fax: +39 039 / 60 53 312

Mitsubishi Electric Europe B.V. **NETHERLANDS**
 Nijverheidsweg 23C
NL-3641RP Mijdrecht
 Phone: +31 (0) 297 250 350

Mitsubishi Electric Europe B.V. **POLAND**
 ul. Krakowska 50
PL-32-083 Balice
 Phone: +48 (0) 12 347 65 00
 Fax: +48 (0) 12 630 47 01

Mitsubishi Electric (Russia) LLC **RUSSIA**
 2 bld. 1, Letnikovskaya st.
RU-115114 Moscow
 Phone: +7 495 / 721 2070
 Fax: +7 495 / 721 2071

Mitsubishi Electric Europe B.V. **SPAIN**
 Carretera de Rubí 76-80 Apdo. 420
E-08190 Sant Cugat del Vallés (Barcelona)
 Phone: +34 (0) 93 / 5653131
 Fax: +34 (0) 93 / 5891579

Mitsubishi Electric Europe B.V. (Scandinavia) **SWEDEN**
 Hedvig Möllers gata 6,
SE- 223 55 Lund
 Phone: +46 (0) 8 625 10 00

Mitsubishi Electric Turkey Elektrik Ürünleri A.Ş. **TURKEY**
 Fabrika Otomasyonu Merkezi
 Şerifali Mahallesi Nutuk Sokak No.5
TR-34775 Ümraniye-İSTANBUL
 Phone: +90 (216) 969 25 00
 Fax: +90 (216) / 526 39 95

Mitsubishi Electric Europe B.V. **UK**
 Travellers Lane
UK-Hatfield, Herts. AL10 8XB
 Phone: +44 (0)1707 / 28 87 80
 Fax: +44 (0)1707 / 27 86 95

Mitsubishi Electric Europe B.V. **UAE**
 Dubai Silicon Oasis
United Arab Emirates - Dubai
 Phone: +971 4 3724716
 Fax: +971 4 3724721

Mitsubishi Electric Corporation **JAPAN**
 Tokyo Building 2-7-3
 Marunouchi, Chiyoda-ku
Tokyo 100-8310
 Phone: +81 (3) 3218-2111
 Fax: +81 (3) 3218-2185

Mitsubishi Electric Automation, Inc. **USA**
 500 Corporate Woods Parkway
Vernon Hills, IL 60061
 Phone: +1 (847) 478-2100
 Fax: +1 (847) 478-0328

EUROPEAN REPRESENTATIVES

GEVA **AUSTRIA**
 Wiener Straße 89
A-2500 Baden
 Phone: +43 (0)2252 / 85 55 20
 Fax: +43 (0)2252 / 488 60

OOO TECHNIKON **BELARUS**
 Prospect Nezavisimosti 177-9
BY-220125 Minsk
 Phone: +375 (0)17 / 393 1177
 Fax: +375 (0)17 / 393 0081

INEA RBT d.o.o. **BOSNIA AND HERZEGOVINA**
 Stegne 11
SI-1000 Ljubljana
 Phone: +386 (0)1 / 513 8116
 Fax: +386 (0)1 / 513 8170

AKHNATON **BULGARIA**
 4, Andrei Ljapchev Blvd., PO Box 21
BG-1756 Sofia
 Phone: +359 (0)2 / 817 6000
 Fax: +359 (0)2 / 97 44 06 1

INEA CR **CROATIA**
 Losinjska 4 a
HR-10000 Zagreb
 Phone: +385 (0)1 / 36 940 - 01 / -02 / -03
 Fax: +385 (0)1 / 36 940 - 03

AutoCont C. S. S.R.O. **CZECH REPUBLIC**
 Kalkova 1853/3
CZ-702 00 Ostrava 2
 Phone: +420 595 691 150
 Fax: +420 595 691 199

HANS FØLSGAARD A/S **DENMARK**
 Theilgaardsgade 1
DK-4600 Køge
 Phone: +45 4320 8600
 Fax: +45 4396 8855

Electrobit OÜ **ESTONIA**
 Pärnu mnt. 160i
EST-11317, Tallinn
 Phone: +372 6518 140

UTU Automation Oy **FINLAND**
 Peltotie 37i
FIN-28400 Uusikaipi
 Phone: +358 (0)207 / 463 500
 Fax: +358 207 / 463 501

UTEKO A.B.E.E. **GREECE**
 5, Mavrogenous Str.
GR-18542 Piraeus
 Phone: +30 (0)211 / 1206-900
 Fax: +30 (0)211 / 1206-999

MELTRADE Kft. **HUNGARY**
 Fertő utca 14.
HU-1107 Budapest
 Phone: +36 (0)1 / 431-9726
 Fax: +36 (0)1 / 431-9727

OAK Integrator Products SIA **LATVIA**
 Rītausmas iela 23
LV-1058 Rīga
 Phone: +371 67842280

Automatikos Centras, UAB **LITHUANIA**
 Neries krantinė 14A-101
LT-48397 Kaunas
 Phone: +370 37 262707
 Fax: +370 37 455605

ALFATRADE Ltd. **MALTA**
 99, Paola Hill
Malta-Paola PLA 1702
 Phone: +356 (0)21 / 697 816
 Fax: +356 (0)21 / 697 817

EUROPEAN REPRESENTATIVES

INTEHSIS SRL **MOLDOVA**
 bld. Traian 23/1
MD-2060 Kishinev
 Phone: +373 (0)22 / 66 4242
 Fax: +373 (0)22 / 66 4280

Fonseca S.A. **PORTUGAL**
 R. João Francisco do Casal 87/89
PT-3801-997 Aveiro, Esgueira
 Phone: +351 (0)234 / 303 900
 Fax: +351 (0)234 / 303 910

SIRIUS TRADING & SERVICES SRL **ROMANIA**
 Aleea Lacul Morii Nr. 3
RO-060841 Bucuresti, Sector 6
 Phone: +40 (0)21 / 430 40 06
 Fax: +40 (0)21 / 430 40 02

INEA SR d.o.o. **SERBIA**
 Ul. Karadjordjeva 12/217
SER-11300 Smederevo
 Phone: +386 (026) 461 54 01

SIMAP SK (Západné Slovensko) **SLOVAKIA**
 Dolné Pažite 603/97
SK-911 06 Trenčín
 Phone: +421 (0)32 743 04 72
 Fax: +421 (0)32 743 75 20

INEA RBT d.o.o. **SLOVENIA**
 Stegne 11
SI-1000 Ljubljana
 Phone: +386 (0)1 / 513 8116
 Fax: +386 (0)1 / 513 8170

OMNI RAY AG **SWITZERLAND**
 Im Schörl 5
CH-8600 Dübendorf
 Phone: +41 (0)44 / 802 28 80
 Fax: +41 (0)44 / 802 28 28

CSC- AUTOMATION Ltd. **UKRAINE**
 4 B, Yevhena Sverstyuka Str.
UA-02002 Kiev
 Phone: +380 (0)44 / 494 33 44
 Fax: +380 (0)44 / 494-33-66

EURASIAN REPRESENTATIVES

TOO Kazpromavtomatika **KAZAKHSTAN**
 UL. ZHAMBYLA 28,
KAZ-100017 Karaganda
 Phone: +7 7212 / 50 10 00
 Fax: +7 7212 / 50 11 50

MIDDLE EAST REPRESENTATIVE

EIM Energy **EGYPT**
 3 Roxy Square
ET-11341 Heliopolis, Cairo
 Phone: +202 24552559
 Fax: +202 245266116

SHERF Motion Techn. Ltd. **ISRAEL**
 Rehov Hamerkava 19
IL-58851 Holon
 Phone: +972 (0)3 / 559 54 62
 Fax: +972 (0)3 / 556 01 82

CEG LIBAN **LEBANON**
 Cebaco Center/Block A Autostrade DORA
Lebanon-Beirut
 Phone: +961 (0)1 / 240 445
 Fax: +961 (0)1 / 240 193

AFRICAN REPRESENTATIVE

ADROIT TECHNOLOGIES **SOUTH AFRICA**
 20 Waterford Office Park 189 Witkoppen Road
ZA-Fourways
 Phone: + 27 (0)11 / 658 8100
 Fax: + 27 (0)11 / 658 8101

Model	FR-D800 TORISETSU KINOU ANZEN EIBUN
Model code	1AJ087

MITSUBISHI ELECTRIC CORPORATION

HEAD OFFICE: TOKYO BUILDING 2-7-3, MARUNOUCHI, CHIYODA-KU, TOKYO 100-8310, JAPAN